

Punching shear check node 1474

The check is led after DIN 1045-1 July 2001.

1. Measurements, situation and material

Rectangular column with width $b_x = 0.40$ m and height $b_y = 0.40$ m

Situation: Inside; $\beta = 1.05$

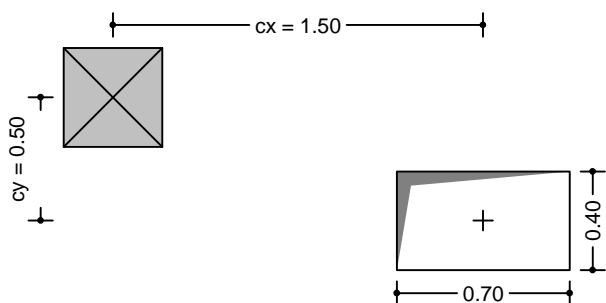

Rectangular aperture with width $l_x = 0.70$ m; height $l_y = 0.40$ m

Pitch related to the emphases $c_x = 1.50$ m; $c_y = 0.50$ m

Critical perimeter $u = 3.53$ m (distance = 0.35 m)

Slab height $h = 0.260$ m

Effective height of the slab $d_x = 0.230$ m; $d_y = 0.230$ m

Available longitudinal reinforcement $a_{sx} = 14.83$ cm²/m; $a_{sy} = 14.83$ cm²/m

Truss angle $\alpha = 90.0^\circ$

Concrete: C20/25 $f_{ck} = 20.00$ N/mm² $\alpha = 0.85$
 $\gamma_c = 1.50$ $f_{cd} = \alpha \cdot f_{ck} / \gamma_c = 11.33$ N/mm²

Reinforce.: BSt 500 $f_{ck} = 500.00$ N/mm² $\gamma_c = 1.15$
 $f_{yd} = f_{yk} / \gamma_s = 434.78$ N/mm²

2. Action from fundamental combination

$V_{Ed} = 736.78$ kN $N_{Ed} = 0.00$ kN/m $\sigma_0 = 0.00$ kN/m²

$V_{Ed} = \beta \cdot V_{Ed} / u = 218.86$ kN/m

3. Punching resistance without punching reinforcement

$$V_{Rd,ct} = (0,14\eta_1\kappa \cdot (100 \cdot \rho_l \cdot f_{ck})^{1/3} - 0,12\sigma_{cd}) \cdot d$$

with $\eta_1 = 1.00$ $\kappa = 1.93$
 $\rho_l = 0.0064$ $f_{ck} = 20.00$ N/mm²
 $\sigma_{cd} = 0.00$ N/mm² $d = 0.23$ m

$V_{Rd,ct} = 145.92$ kN/m

$V_{Ed} / V_{Rd,ct} = 1.50 > 1$ Punching reinforcement is required!

4. Punching reinforcement (normal)

$$A_{sw,1} = \frac{(V_{Ed} - V_{Rd,c}) \cdot u_1}{\kappa_s \cdot f_{yd}} \quad A_{sw,i} = \frac{(V_{Ed} - V_{Rd,c}) \cdot u_i \cdot s_w}{\kappa_s \cdot f_{yd} \cdot d}$$

$A_{sw,min} = \min p_w \cdot s_w \cdot u_i$

with $V_{Rd,c} = 145.92$ kN/m $f_{yd} = 434.78$ N/mm²
 $\kappa_s = 0.70$ $s_w = 0.172$ m

4. Punching reinforcement (normal)

$$\min p_w = 0.070 \% \quad d = 0.23 \text{ m}$$

Row 1:	Distance = 0.12 m;	$u_1 = 2.18 \text{ m}$;	$V_{Ed,1} = 354.56 \text{ kN/m}$;	$A_{sw,1} = \mathbf{14.96 \text{ cm}^2}$	$> A_{sw,1,min} = 2.63 \text{ cm}^2$
Row 2:	Distance = 0.29 m;	$u_2 = 3.19 \text{ m}$;	$V_{Ed,2} = 242.30 \text{ kN/m}$;	$A_{sw,2} = \mathbf{7.56 \text{ cm}^2}$	$> A_{sw,2,min} = 3.84 \text{ cm}^2$
Row 3:	Distance = 0.46 m;	$u_3 = 4.21 \text{ m}$;	$V_{Ed,3} = 183.89 \text{ kN/m}$;	$A_{sw,3} = 3.92 \text{ cm}^2$	$< A_{sw,3,min} = \mathbf{5.07 \text{ cm}^2}$
Row 4:	Distance = 0.63 m;	$u_4 = 5.22 \text{ m}$;	$V_{Ed,4} = 148.16 \text{ kN/m}$;	$A_{sw,4} = 0.29 \text{ cm}^2$	$< A_{sw,4,min} = \mathbf{6.29 \text{ cm}^2}$

External perimeter: Distance = 0.98 m; $u_a = 7.26 \text{ m}$; $V_{Ed,a} = 106.61 \text{ kN/m}$; $\kappa_a = 0.773$; $V_{Rd,ct,a} = 112.75 \text{ kN/m}$

$V_{Ed,a} \leq V_{Rd,ct,a}$ The check is OK!

5. Minimum momenta and corresponding longitudinal reinforcement according to section 10.5.6

$$m_{Ed,x} = \eta_x \cdot V_{Ed} = 0.125 \cdot 736.78 = 92.10 \text{ kNm/m}$$

$$\text{corresponding longitudinal reinforcement } a_{sx,min} = 9.84 \text{ cm}^2/\text{m} \leq a_{sx} = 14.83 \text{ cm}^2/\text{m}$$

$$m_{Ed,y} = \eta_y \cdot V_{Ed} = 0.125 \cdot 736.78 = 92.10 \text{ kNm/m}$$

$$\text{corresponding longitudinal reinforcement } a_{sy,min} = 9.84 \text{ cm}^2/\text{m} \leq a_{sy} = 14.83 \text{ cm}^2/\text{m}$$